



Figure 1 Automatic-Recirculation-Check Valve SSV 48 with control disc and bearing plate

Application

The Automatic-Recirculation-Check Valve (AR-Valve) is a pump protection device. It automatically protects centrifugal pumps from damage which might occur through partial evaporation of the fluid content during low load operation.

- Power Stations, Nuclear Power Stations
- Chemical industry
- Petrochemical industry
- Off-Shore-Industries
- Paper industry
- Fire fighting systems
- Snow producing systems
- In the potable water supply and backwater disposal

The SSV 40 up to SSV 48 is especially designed for centrifugal pumps with high bypass flow and low pressure load up to 400 m.

Design and Operation

For the main flow - to the process - the valves have an inlet flange DN₁ and an outlet flange DN₂. The minimum flow is going out through an additional branch DN₃ back to the reservoir.

As soon as the pump capacity drops below a predetermined flow rate, the AR-valve opens sufficiently the bypass to maintain the pump minimum flow rate. This rate is maintained even if the flow in main direction to the boiler or process is completely shut off.

The AR-valve automatically opens and closes the bypass corresponding to the main flow rate. This **flow controlled** function operates without additional auxiliary energy.

The pressure and flow reduction to the minimum flow requirements in the bypass line takes place through a multistage throttle system.

Advantage and Utility

- for high bypass flow at low pressure load
- assurance of the required pump minimum continuous safe flow no inadmissible temperature increase in the pump; avoidance of cavitations in the pump; avoidance of pump and plant damages
- integrated non-return valve in the main delivery stream avoidance of reverse operation of the pump; allows parallel pump operation
- favorable NPSH-value of the plant (NPSH_A) and the pump (NPSH_R) lower capacity in operating point because of automatic closure of the minimum flow line
- lower prime mover power requirement
- lower facility costs

Special Features

- modulating bypass control with low wear by the „Control-Disc-Design“
- non-return-function in main direction to the process
- multistage reduction of pressure and flow rate in the bypass - low cavitations and of low noise
- without additional auxiliary energy and measuring technique
- less pressure loss
- mounting position vertical* or horizontal
- all internal parts are made out of stainless steel
- reliable and durable

Technical Data SSV 40 up to SSV 48

Medium	
Fluids without solids	
Viscosity	≤ 150 cSt
Temperature	-10 °C up to +300 °C* -14 °F up to +572 °F*
Engineering Specification	
Nominal width DN	
• main direction	50 up to 600 mm; (2" up to 24")*
• bypass	25 up to 350 mm (1" up to 14")*
Pressure rate	PN 10 up to PN 63* ANSI 150 up to ANSI 300 lbs*
Bypass control	modulating with throttle
Material casing parts	1.0460 (A105)* ASME in () 1.0566 (A350-LF2); 1.4301 (A182-F304); 1.4541 (A276-321); 1.4571 (A276-316TI); 1.4404 (A182-F316L); 1.4462 (A182-F51); further materials by request
Material internals	stainless steel*
Connection	Flanges according to DIN / ANSI* Sealing and connection parts are not scope of supply
Mounting position	vertical* or horizontal
Operating Condition	
Pressure difference between inlet (DN ₁) and Bypass branch (DN ₃)	max. 40 bar max. 580 psi
Flow rate main direction	14 m ³ /h up to 4500 m ³ /h* 62 USgpm up to 19800 USgpm*
Flow rate bypass	up to 1800 m ³ /h* (7920 USgpm)* 50%, max. 60% of main flow rate is advised*
Flow velocity	max. 10 m/s (flange)
Pressure loss in the valve (applied to main flow)	appr. 0,4 up to 0,5 bar

* standard version, more by request

Design

The construction is according to specification AD 2000 and particularly to EN 13445. As per Pressure Equipment Directive 97/23 EC the products are provided with the CE marking and the Declaration of Conformity. Certified according to the Module H1 (Pressure Equipment Directive 97/23 EC) all dangerous material classes of category 1 to 4 are covered.

Installation and Connection

The AR-valve is produced and tested only for the ordered data according the customer data sheet. Following points have to be alluded:

- Mounting direct on the pump discharge branch (advised)
- Pipes have to be connected free of stress, without offset, mismatch or longitudinal shifting
- The pipe system must be cleaned and free of soiling
- Installation has to be in the ordered mounting position
- To maintain the valve and to calm down the flow a piece of straight pipe with a length of 1 meter (40") has to be installed at the bypass branch DN₃ and at the outlet branch DN₂
- The bypass pipe has to be filled with medium anytime
- The supplied installation and operating instructions has to be followed

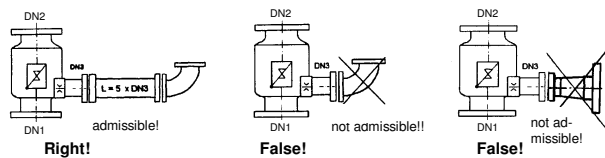

Figure 2 Mounting with straight pipe piece

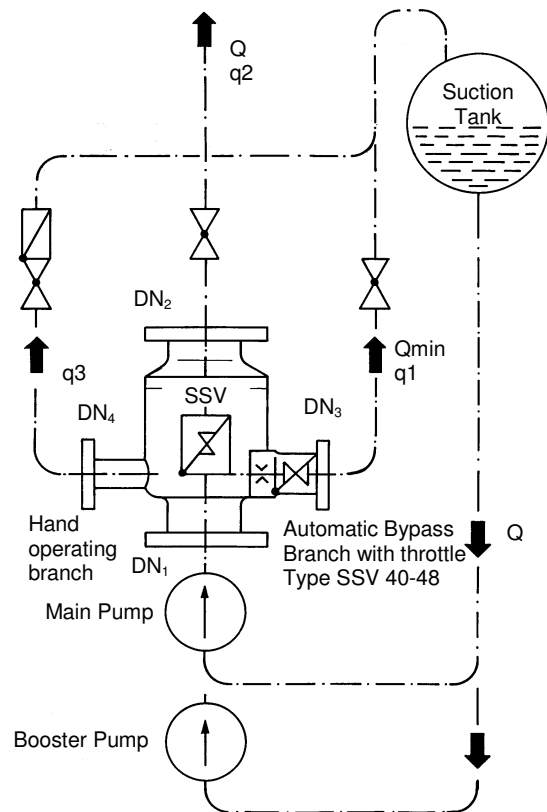

Figure 3 Bypass Return with additional hand operated branch (optional)

Note of Application

The operator of these fittings is responsible for suitability, proper use and corrosion resistance of the used materials with regard to the used fluid. It must be ensured that the materials selected for the fitting parts in contact with the medium are suitable for the used process media. The fitting may only be used for the application specified in the operating instructions and the data sheets. Provide a touch guard for surface temperatures of < -10 °C or > +50 °C. This touch guard must be designed in a way that the max. allowable ambient temperature on the unit is not exceeded. Before replacing the valve, check that the unit is free of hazardous media and pressures.

Type Designation of the Valves

The designation of the valve specifies the type, nominal width and pressure rate, the flange sizes and the mounting position.

Example:

	SSV 40 - 50 / 25	- 50 / 50 / 25 / 0 - 1					
	SSV 40 - 2" ANSI150	- 2 / 2 / 1 / 0 - 1					
Valve type	↑ 40	↑ 50	↑ 25	↑ 50	↑ 50	↑ 25	↑ 0
with control disc		2"	ANSI150	2	2	1	0
Valve size							
DN 50 mm							
DN 2" (ANSI)							
Pressure rate							
25 bar							
150 lbs. (ANSI)							
Flange sizes							
inlet DN ₁ 50 mm							
inlet DN ₁ 2" (ANSI)							
outlet DN ₂ 50 mm							
outlet DN ₂ 2" (ANSI)							
bypass DN ₃ 25 mm							
bypass DN ₃ 1" (ANSI)							
additional branch							
no additional branch							
mounting (applied to main flow)							
vertical							1
horizontal							2

2/3

SSV 40 up to SSV 48

At the type SSV 40 up to SSV 48 the number indicates the size of the valve and the control disc design.

Typ	Nominal Size		Max. Bypass Flow	
	Valve	Bypass Branch	pressure loss	DN ₁ /DN ₃ Δp = 10 bar
	DN	DN ₃	Q _{By max}	Q _{By max}
	[mm]	[mm]	[m ³ /h]	[USgpm]
SSV 40	50 - 80	25 / 40	32	141
SSV 41	80 - 125	40 / 50	63	277
SSV 42	100 - 150	65 / 80	133	586
SSV 43	150 - 250	100 / 125	250	1101
SSV 44	200 - 400	125 / 150	380	1673
SSV 45	250 - 400	125 / 150	545	2400
SSV 46	300 - 500	150 / 250	900	3963
SSV 47	350 - 600	200 / 300	1010	4447
SSV 48	350 - 600	250 / 350	1620	7133

Marking of the Valve

The Automatic-Recirculation-Check Valve has the following name plate with all relevant valve data.

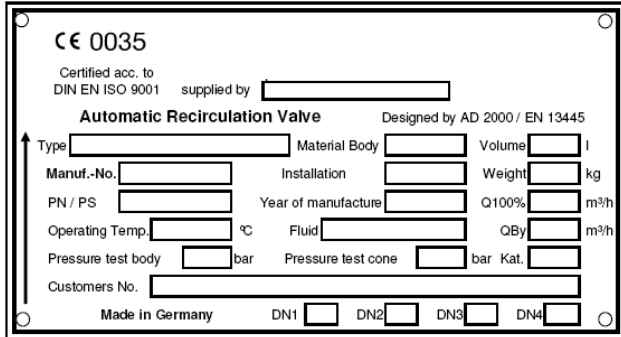

Figure 4 Name plate mounted to the fitting

Accessories

The **hand operating branch** with multiport-throttle is fitted at the casing below the cone seat and serves to pass off the minimum flow via a hand-operated valve combination. We recommend the branch for protection of the internal bypass parts at extreme operating conditions, e.g. at high differential pressures and frequent operation in the range of bypass flow as well as for filling and start-up of the plant.

Warm-up branch, pressure gauge branch, draining branch etc. can be provided, if required.

The **damping valve SRV** will be applied to absorb pressure shocks during recurrent on/off operation e.g. for descaling facilities at steel mills. The SRV has to be mounted direct to the AR-Valve.

Parts List SSV 40 up to SSV 48 with Control Disc and Throttle

Part-#	Designation	Materials
1	Lower body	
2	Upper body	

Part-#	Designation	Materials
3	Cone	
4	Cone guide	
5	Cone guide	
30	Bypass branch	
31	Adapter	
32	Lever	
33	Toothed segment	
34	Bearing pin	
35	Pin cover plate	
36	Carrier plate	
37	Control disc	according to operating conditions and valid standards
38	Bearing plate	
40	Throttle	
90.1	Eye bolt	
91.1	Socket screw	
91.2	Socket screw	
91.3	Socket screw	
92	Cap nut	
94.1	Dowel pin	
94.2	Dowel pin	
94.3	Dowel pin	
95.3	Coil spring	

Wear and Spare Parts

3/3

Control disc and bearing plate	
Control disc	Part-# 37
Bearing plate	Part-# 38
Dowel pin	Part-# 94.3
Single Spare Parts	
Coil spring	Part-# 95.1

With reservation to changes

SSV40-SSV48_en_03

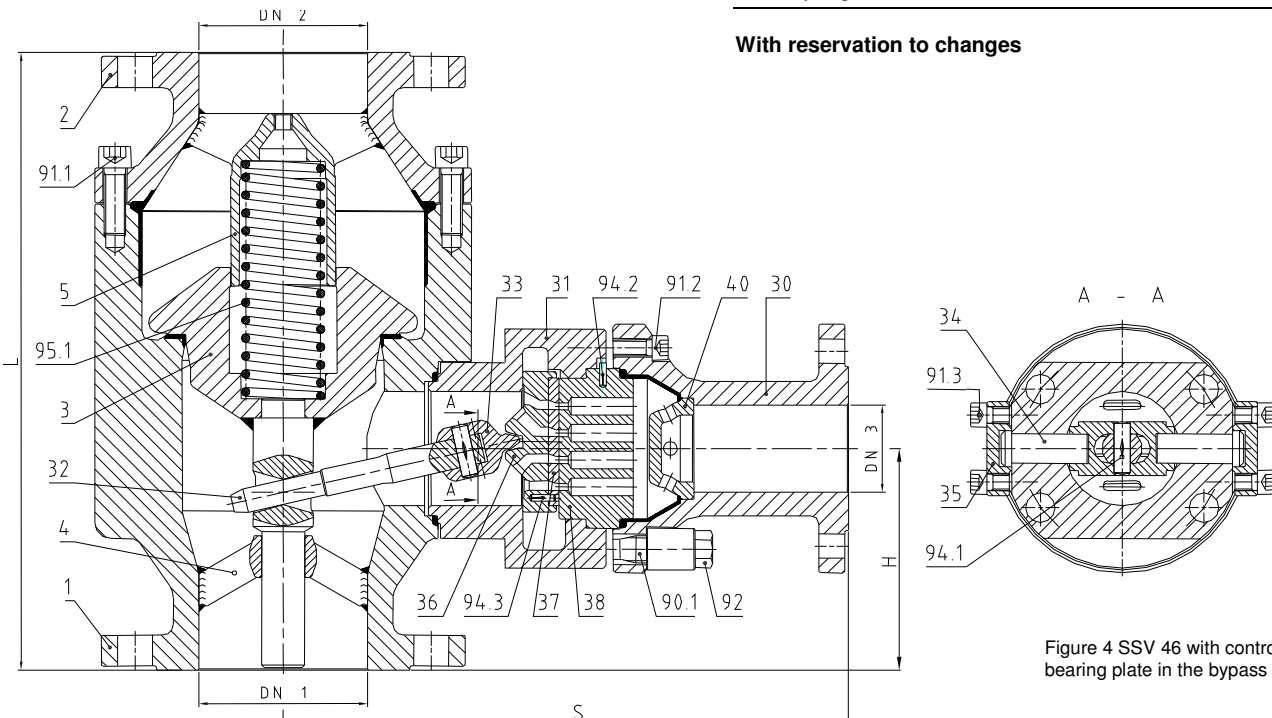

Figure 4 SSV 46 with control disc and bearing plate in the bypass