

- large filtration area - increasing of the endurance
- short delivery times by standard sizes (ANSI 150 and 300)



Figure 1 Y-Type Strainer

### Application

The Y-Type Strainer is the most common and economical type of strainer for permanent applications, suitable for liquid, steam and gas mediums. Due to the compact and low weight construction the easy and quick cleaning are Y-Type Strainers used in manifoldly manners like:

- pump protection,
- flow meter protection,
- valve and regulator protection,
- protection of heat exchanger and refrigerating set,
- protection of steam traps,
- instrumentation and ancillary piping item protection

### Design and Operation

The Y-Strainers consists of a housing with opposite arranged in- and outlet flanges at the same level. Between these connections is a basket strainer made of a perforated plate, optionally covered with a cloth consisting of various materials and mesh widths. The medium to be filtered will enter the filter from the inside to the outside. Hence, the contaminations will remain within the strainer insert. The Y-Strainer could be depressurizing through the venting or draining devices. After removing of the flap the complete basket strainer could be easily removed out of the filter housing. Now the strainer can be cleaned by blowing out or blasting using compressed air, steam, or water. If necessary, the strainer should be soaked and cleaned using a suitable agent. Possibly, an optimal cleaning will be obtained using ultrasonics. The housing could be manufactured by forged steel, cast iron or a weldment (pipes and flanges).

Y-Strainer can be installed both in the horizontal and vertical positions without any effect on performance providing the screen is installed in the downward position to assist draining and cleaning operations.

### Advantage and Utility

- reasonable strainer
- standard types available from stock
- permanent filtration of the medium
- suitable for mounting in horizontal and vertical pipelines
- no disassemble of the filter housing for cleaning is necessary
- simple handling / basket cleansing
- low-maintenance
- reusable elements
- contamination level indicator (optional)

### Special Features

The Y-Type Strainers convince through the following characteristic features:

- less pressure drop

### Technical Data

<b>Medium</b>	
liquids, steams, gases or mixtures	
<b>Engineering Specification</b>	
Flange nominal width	DN 15 to 1200 (1/2" to 48")
Operating Pressure	PN 16 to PN 250* (ANSI 150 to ANSI 1500 lbs)*
Filter fineness (Mesh sizes)	400 $\mu\text{m}$ * (Standard) or acc. to requirement
Connection	Flanges acc. to ANSI / DIN
<b>Material*</b>	
Housing (Pos. 1)	1.0169 (A216 WCB) 1.4408 (A315 CF8M)
Filter element (Pos. 2)	1.4401 (316)
Surface treatment	one coat of red oxide* (carbon steel)
Fitting position	Horizontal or vertical
Direction of flow	lateral or from top to down

#### Accessories

- Differential pressure meter
- Magnetic filter element
- Drain nozzle with flange; drain valve
- Special lining
- Special painting
- Special design
- Special seals

#### Certificates

DGR 97/23/EG  
CE-Confirmation

\* standard design, other on customer's request

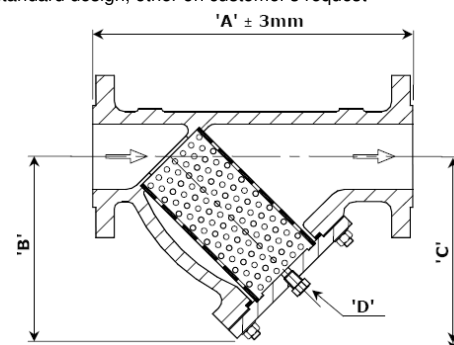

Figure 2 Y-Strainer with flanges

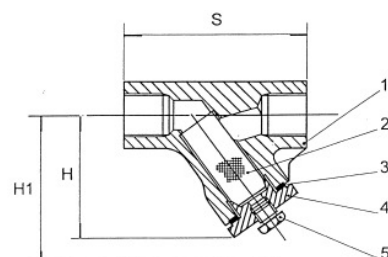

Figure 3 Y-Type Strainer with NPT- or socket weld