



Figure 1 Mono-in-Line Strainer

### Application

Mono-In-Line Strainers offer a larger filtration area than similar strainers on the market, ensuring minimal pressure loss, improved flow-rates and greater dirt holding capacity, leading on longer service / maintenance intervals. They are used for the following example applications:

- pump protection,
- flow meter protection,
- valve and regulator protection,
- protection of heat exchanger and refrigerating set,
- protection of steam traps,
- instrumentation and ancillary piping item protection

### Design and Operation

The Mono-In-Line Strainer consists of a cast-iron housing with opposite connecting flanges arranged at the same level. Between these connections is the basket strainer with carrying strap located. The filter insert consists of a perforated plate, alternatively covered with cloths having different mesh widths. The medium to be filtered will enter the filter from above and flows through the insert from the inside to the outside. Hence, the contaminations will remain within the strainer insert.

The Mono-In-Line Strainer could be depressurizing through the venting or draining devices. After removing of the quick release closure the complete basket strainer could be easily removed out of the filter housing through the carrying strap. Now the strainer is ready for cleaning (see sheet "Y-Type Strainer" Design and Operation). The housing could be manufactured by cast iron or single-piece production

### Advantage and Utility

- efficient and reasonable strainer
- permanent filtration of the medium
- no disassemble of the filter housing for cleaning is necessary
- short filter allowance by strainer with quick release closure
- simple handling / basket cleansing
- low-maintenance
- reusable elements
- contamination level indicator (optional)

### Special Features

The Mono-In-Line Strainers convince through the following characteristic features:

- less pressure drop
- large filtration area - increasing of the endurance
- safety locking acc. to ASME VIII UG-35(b) and British Gas E13
- short delivery times by standard sizes (ANSI 150 and 300)

### Technical Data

#### Medium

liquids, steams, gases or mixtures

#### Engineering Specification

Flange nominal width	DN 15 to 900 (1/2" to 36")
Operating Pressure	PN 16 to PN 320* ANSI 150 to ANSI 2500 lbs*
Filter fineness (Mesh sizes)	400 µm* (or acc. to requirement)
Connection	Flanges acc. to ANSI / DIN
Material*	ASME in ( )
Housing	1.0169 (A216 WCB)* 1.4408 (A315 CF8M)*
Filter element	1.4401 (316)*
Surface treatment	one coat of red oxide* (carbon steel)
Fitting position	horizontal or vertical
Direction of flow	lateral or from top to down

#### Accessories

- Differential pressure meter
- Safety interlock against accidental release of the quick release closure
- Magnetic filter element
- Drain nozzle with flange; drain valve
- Special lining
- Special painting
- Special design
- Special seals

#### Special design as Multi Basket Strainer

With several basket strainers for:

- high flow rates
- less pressure drop
- heavily polluted mediums

#### Certificates

DGR 97/23/EG  
CE-Confirmation

\* standard design, other on customer's request

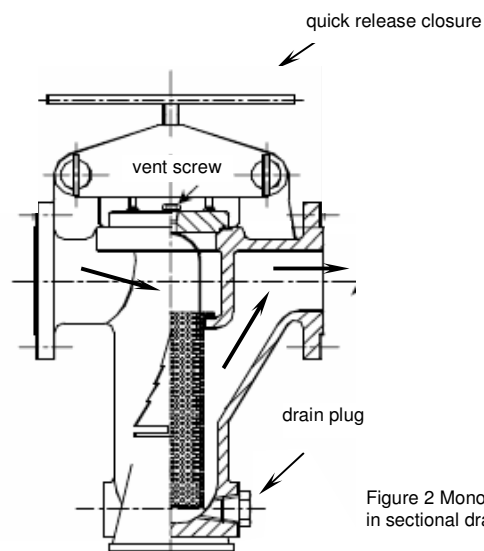

Figure 2 Mono-In-Line Strainer in sectional drawing