

Figure 1 FIRPLEX - Strainer

## Application

Duplex strainers can be used in a versatile manner to filter coarse and fine particles. They are used in many liquid system applications. The main advantage of this design is that two filter chamber construction allows continuous operation without any shut down for cleaning the component, unlike Y-Type or Mono In Line Type which must be isolated from the process for maintenance. Other advantages of the FIRPLEX - strainer is the large filtration area, which provides a high filtration capacity, as well as quick and easy access for cleaning.

The change-over between on-line and standby is achieved by utilising the integral valve system, controlled by a single lever. Duplex strainers are typically used for the following filtration areas:

- Pump- and Compressor Protection,
- Flow meter Protection,
- Protection of Control and Relief Valves,
- Protection of Heat Exchangers and Chillers,
- Protection of Steam Traps,
- Protection of Instruments, Valves and other Process Equipment

## Design and Operation

The FIRPLEX strainer is a single housing assembly with an opposing Inlet- and Outlet flange. Each housing assembly comprises 2 identical filter chambers bolted to a central ball valve diverter chamber. By operation of a single lever the flow can be diverted from one filter chamber to the second filter chamber without any need for flow interruption. This enables the operator to clean either basket without any requirement to take the system off-line. Housed in each filter chamber is basket strainer made of a perforated plate, optionally covered with a wire-cloth consisting of various materials and mesh widths. The medium to be filtered flows through the basket from the inside to the outside, hence the contaminants will remain within the strainer basket upon removal from the chamber.

## Advantage and Utility

- large filtration area
- permanent filtration of the medium even during maintenance
- competitively priced within its field
- standard types available from stock
- no "down-time" during maintenance / basket cleaning
- single lever operation for safety and simplicity
- simple handling / basket cleaning
- low-maintenance
- reusable elements

## Special Features

The Duplex Strainer series FIRPLEX has many advantageous characteristics & features:

- permits change over of filter chambers, enabling contaminated basket to be taken off line without interruption of flow
- low pressure drop
- ball valve system provides positive seal between chambers for liquid applications
- single lever for ease of operation requiring low torque
- standard sizes available from stock – DN25mm to DN100mm

## Technical Data

<b>Medium</b>	
Liquids up to 93°C	
<b>Engineering Specification</b>	
Flange nominal diameter	DN 25 to 100 (1" to 4")
Operating Pressure	PN 16 ANSI 150#
Filter fineness (Mesh sizes)	400 µm (standard or acc. to requirement)
Connection	Flanges acc. to ANSI / DIN
<b>Material</b>	
Housing	1.0619 (A216 WCB)* 1.4408 (A351 CF8M)*
Filter element	1.4404 (316)*
Surface treatment	One coat of red oxide* (carbon steel)
Fitting position	horizontal only
Direction of flow	In- and outlet on same level
<b>Accessories</b>	

- Drain nozzle with flange; drain valve
- Special painting
- Special filter design
- Special seals
- Special design

<b>Certificates</b>	
PED 97/23/EC CE-Confirmation to S.E.P. ≤DN25 (1")	
* standard design, other on customer's request	

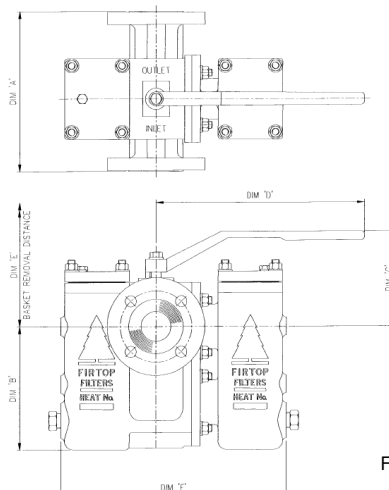

Figure 2 FIRPLEX - Strainer