

Flow Measurement

SITRANS F C

Transmitter MASS 6000 for 19" insert/19" wall mounting

Overview



MASS 6000 is based on the latest developments within digital signal processing technology – engineered for high performance, fast flow step response, fast batching applications, high immunity against process noise, easy to install, commission and maintain.

The MASS 6000 transmitter delivers true multi parameter measurements i.e.: Mass flow, volume flow, density, temperature and fraction.

The MASS 6000 19" transmitter can be connected to all sensors of types MASS 2100/MC2/FC300 and are available in different versions depending of number of output facilities, Ex protection and grade of enclosure.

Benefits

- Dedicated mass flow chip with the latest ASIC technology
- Fast batching and flow step response with an update rate of true 30 Hz
- Superior noise immunity due to a patented DFT (Discrete Fourier Transformation) algorithm.
- Front end resolution better than 0.35 ns improves zero point stability and enhances dynamic turn-down ratio on flow and density accuracy.
- Advanced diagnosis and service menu enhances troubleshooting and meter verification.
- Built-in batch controller with compensation and monitoring comprising 2 built-in totalizers
- Multi-parameter outputs, individual configurable for mass flow, volume flow, density, temperature or fraction flow such as BRIX or PLATO
- Many output capacities, up to 3 current, 2 frequency/pulse and 2 relay outputs (excludes the possibility of an add-on module)
- Digital input for batch-control, remote zero adjust or forced output mode
- All outputs can be forced to preset value for simulation, verification or calibration purposes.
- User-configurable operation menu with password protection
 - 3 lines, 20 characters display in 11 languages
 - Self-explaining error handling/log in text format
 - Keypad can be used for controlling batch as start/stop/hold/reset

- SENSORPROM technology automatically configures transmitter at start-up providing:
 - Factory pre-programming with calibration data, pipe size, sensor type, output settings
 - Any values or settings changed by users are stored automatically
 - Automatically re-programming any new transmitter without loss of accuracy
 - Transmitter replacement in less than 5 minutes. True "plug & play"
- 4-wire Pt1000 temperature measurement ensures optimum accuracy on mass flow, density and fraction flow
- Fraction flow computation based on a 5th-order algorithm matching all applications
- USM II platform enables fitting of add-on bus modules without loss of functionality.
 - All modules can be fitted as true "plug & play"
 - Module and transmitter automatically configured through the SENSORPROM.
- Transmitter available with ATEX and UL approval
- All electrical connections are easily accessible on the large back plane PCB

Application

SITRANS F C Coriolis mass flowmeters are suitable for all applications within the entire process industry, where there is a demand for accurate flow measurement. The meter can measure both liquids and gases.

The main applications for the MASS 6000 19" transmitter can be found in:

- Chemical and pharmaceutical industries
- Food and beverage industries
- Automotive industry
- Oil and gas industry
- Power generation and utility industry
- Water and waste water industry

Design

The transmitter is designed as a 19" insert as base to be used in:

- 19" rack system
- Panel mounting IP66/NEMA 4
- Back of panel mounting IP20/NEMA 1
- Wall mounting IP66/NEMA 4

The MASS 6000 19" is available as standard or as ATEX-approved transmitter which is to be mounted in the safe area.

Flow Measurement

SITRANS F C

Transmitter MASS 6000 for 19" insert/19" wall mounting

Function

The following functions are available:

- Mass flow rate, volume flow rate, density, temperature, fraction flow
- 2 output versions available as standard:
 - 1 current output, 1 frequency/pulse output, 1 relay output, 1 digital input
 - 3 current outputs, 2 frequency/pulse outputs, 2 relay outputs, 1 digital input
- All outputs can be individually configured with mass, volume, density etc.
- 2 built-in totalizers which can count positive, negative or net
- Low flow cut-off
- Density cut-off or empty pipe cut-off, adjustable
- Flow direction
- Error system consisting of error-log, error pending menu
- Operating time
- Uni/bidirectional flow measurement
- Limit switches with 1 or 2 limits, programmable for flow, density or temperature
- Noise filter setting for optimization of measurement performance under non-ideal application conditions
- Full batch controller
- Automatic zero adjustment menu, with zero point evaluation feed-back
- Full service menu for effective and straight forward application and meter troubleshooting

Technical specifications

Measurement of	Mass flow [kg/s (lbs/min)], volume flow [l/s (gpm)], fraction [%], °Brix, density [kg/m ³ (lbs/ft ³)], temperature [°C (°F)]
Current output	
Current	0 ... 20 mA or 4 ... 20 mA
Load	< 800 Ω
Time constant	0 ... 99.9 s adjustable
Digital output	
Frequency	0 ... 10 kHz, 50 % duty cycle
Time constant	0 ... 30 s adjustable
Active	24 V DC, 30 mA, 1 KΩ ≤ R _{load} ≤ 10 KΩ, short-circuit-protected
Passive	3 ... 30 V DC, max. 110 mA, 1 KΩ ≤ R _{load} ≤ 10 KΩ
Relay	
Type	Change-over relay
Load	42 V/2 A peak
Functions	Error level, error number, limit, direction
Digital input	
Functionality	11 ... 30 V DC Start/hold/continue batch, zero point adjust, reset totalizer 1/2, force output, freeze output
Galvanic isolation	
	All inputs and outputs are galvanically isolated, isolation voltage 500 V.
Cut-off	
Low-flow	0 ... 9.9 % of maximum flow

Limit function	Mass flow, volume flow, fraction, density, sensor temperature
Totalizer	Two eight-digit counters for forward, net or reverse flow
Display	<ul style="list-style-type: none"> • Background illumination with alphanumeric text, 3 × 20 characters to indicate flow rate, totalized values, settings and faults • Reverse flow indicated by negative sign
Zero point adjustment	Via keypad or remote via digital input
Ambient temperature	
Operation	-20 ... +50 °C (-4 ... +122 °F)
Storage	-40 ... +70 °C (-40 ... +158 °F) (Humidity max. 95 %)
Communication	Add-on modules: HART, PROFIBUS PA and DP, MODBUS RTU RS 485, DeviceNet, FOUNDATION Fieldbus H1
Enclosure 19"	
Material	Aluminium/steel (DIN 41494)
Rating	IP20/NEMA 1 to IEC 529 and DIN 40050 (1 mH ₂ O for 30 min.)
Mechanical load	18 ... 1000 Hz random, 3.17G rms, in all directions, to IEC 68-2-36
Supply voltage	<ul style="list-style-type: none"> • 87 ... 253 V AC +10 % ... -10 %, 50 ... 60 Hz • 18 ... 30 V DC or 20 ... 30 V AC
Power consumption	
230 V AC	9 VA max.
24 V DC	6 W I _N = 250 mA, I _{ST} = 2 A (30 ms)
EMC performance	
Emission	EN/IEC 61000-6-4 (Industry)
Immunity	EN/IEC 61000-6-2 (Industry)
Ex approval	[EEx ia] IIC, DEMKO 03 ATEX 135251X
Maintenance	The flowmeter has a built-in error log/pending menu which should be inspected on a regular basis.
Fuse	T 400 mA, T 250 V (IEC 127), not replaceable by operator
Cable	<ul style="list-style-type: none"> • Max. 300 m • C: max. 300 [pF/m]; L_C/R_C: max. 100 [μH/Ω] • The total cable capacity must be max. 200 nF.
Cable glands	The cable gland is available in polyamide, in dimension: PG 13.5

Flow Measurement SITRANS F C

Transmitter MASS 6000 for 19" insert/19" wall mounting

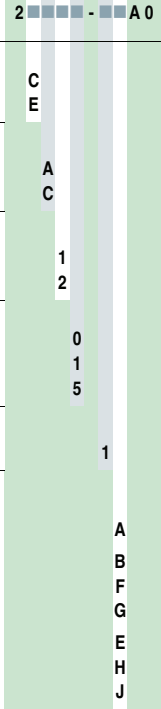
Selection and Ordering data	Order No.
SITRANS F C MASS 6000 transmitter Transmitter for rack and wall mounting, incl. connection board	7ME 4 1 1 0 -
Enclosure 19 inch insert IP20/NEMA 1 (rack) 19 inch insert in IP66/NEMA 4 (wall mounting)	2  A 0
Output configuration 1 current, 1 frequency, 1 relay 3 current, 2 frequency, 2 relay	C E
Supply voltage 115/230 V AC, 50/60 Hz 24 V AC/DC	A C
Ex Approvals Standard (No Ex-approval) ATEX UL Class 1, Div. 2 (only IP66/NEMA 4 version)	1 2
Display/Keypad With display	0 1 5
Serial communication (Only possible to connect to MASS 6000 version with 1 current output) No communication	A B F G
HART PROFIBUS PA Profile 3 PROFIBUS DP Profile 3 MODBUS RTU RS 485 DeviceNet FOUNDATION Fieldbus H1	E H J





Attention (Ex applications)!

MC2 Ex version sensors must only be connected to MASS 6000 standard. The MASS 6000 connection board must be replaced by a connection board approved FDK-083H4294 or FDK-083H4295 (see connection boards/PCB for MASS 6000 and MC2 sensors).

Please also see www.siemens.com/SITRANSOrdering for practical examples of ordering

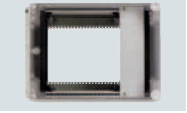
Accessories

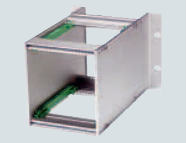
Enclosure

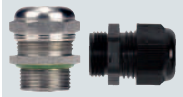

Description	Order No.
Enclosure in ABS plastic for front panel mounting IP66/NEMA 4, for one 19" transmitter insert (21 TE)	FDK-083F5030 
Enclosure in ABS plastic for front panel mounting IP66/NEMA 4, for two 19" transmitter inserts (42 TE)	FDK-083F5031 
Enclosure in aluminium for back of panel mounting IP20/NEMA 1, for one 19" transmitter insert (21 TE)	FDK-083F5032 
Enclosure in aluminium for back of panel mounting IP20/NEMA 1, for two 19" transmitter inserts (42 TE)	FDK-083F5033 
Front cover (7 TE)	FDK-083F4525

Cable glands

Description	Order No.
Cable glands, screwed entries type PG 13.5 in nickel-plated brass, 2 pcs.	FDK-083G3140 
Cable glands, screwed entries type PG 13.5 in polyamide (100 °C (212 °F)) black, 2 pcs.	FDK-083G0228

Spare parts 19" versions

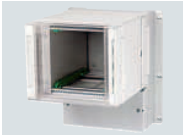
Enclosure (without PCB, connection board)

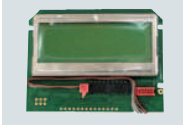
Description	Order No.
Enclosure in ABS plastic for wall mounting IP66/NEMA 4, for one 19" transmitter insert (21 TE), connection board not included	FDK-083F5037 
Enclosure in ABS plastic for wall mounting IP66/NEMA 4, for two 19" transmitter inserts (42 TE), connection board not included	FDK-083F5038 
Display only	FDK-085U3349 

Operating instructions for SITRANS F C MASS 6000 19"

Description	Order No.
Operating instructions for SITRANS F C MASS 6000 19" • English	A5E02944875
This device is shipped with a Quick Start guide and a CD containing further SITRANS F literature.	
All literature is also available for free at: http://www.siemens.com/flowdocumentation	

Add-on module

Note:
Only possible to connect to MASS 6000 versions with 1 current output

Description	Order No.
HART	FDK-085U0226
PROFIBUS PA Profile 3	FDK-085U0236
PROFIBUS DP Profile 3	FDK-085U0237
MODBUS RTU RS 485	FDK-085U0234
FOUNDATION Fieldbus H1	A5E02054250
DeviceNet	FDK-085U0229





Flow Measurement

SITRANS F C

Transmitter MASS 6000 for 19" insert/19" wall mounting

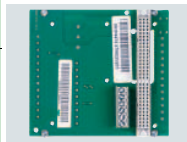
Connection boards/PCB for MASS 6000 and MASS 2100 sensors

Description	Version	Order No.	
Connection board MASS 6000 for 19" IP20 rack mounting version	24 V 115/230 V	FDK-083H4272	
Connection board MASS 6000 EEx [ia] IIC for 19" IP20 rack mounting version	24 V 115/230 V	FDK-083H4273	
Connection board MASS 6000 for 19" wall mounting version, for enclosure FDK-083F5037/FDK-083F5038	24 V 115/230 V	FDK-083H4274	
Connection board MASS 6000 EEx [ia] IIC for 19" wall mounting version, for enclosure FDK-083F5037/FDK-083F5038	24 V 115/230 V	FDK-083H4275	

Connection boards/PCB for MASS 6000 and MC2 sensors

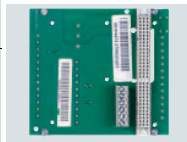
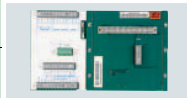
Description	Version	Order No.	
Connection board MASS 6000 for 19" IP20 rack mounting version	24 V 115/230 V	FDK-083H4272	
Connection board MASS 6000 for Ex application ¹⁾ and 19" IP20 rack mounting version (connection board MASS 6000 to MC2 sensors Ex-approved)	24 V 115/230 V	FDK-083H4294	
Connection board MASS 6000 for 19" wall mounting version, for enclosure FDK-083F5037/FDK-083F5038	24 V 115/230 V	FDK-083H4274	
Connection board MASS 6000 for Ex application ¹⁾ and 19" wall mounting version (connection board MASS 6000 to MC2 sensors Ex-approved), for enclosure FDK-083F5037/FDK-083F5038	24 V 115/230 V	FDK-083H4295	

¹⁾ Attention (Ex application): MC2 Ex version sensors must only be connected to connection board FDK-083H4294 or FDK-083H4295.

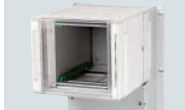
Description	Order No.	
Wall mounting enclosure for MASS 6000 19" version IP66/NEMA 4 (21 TE) with connection board/PCB for Ex application connected to MC2 Ex sensors	FDK-083H4296	

Flow Measurement SITRANS F C

Transmitter MASS 6000
for 19" insert/19" wall mounting

Dimensional drawings

Transmitter 19" insert

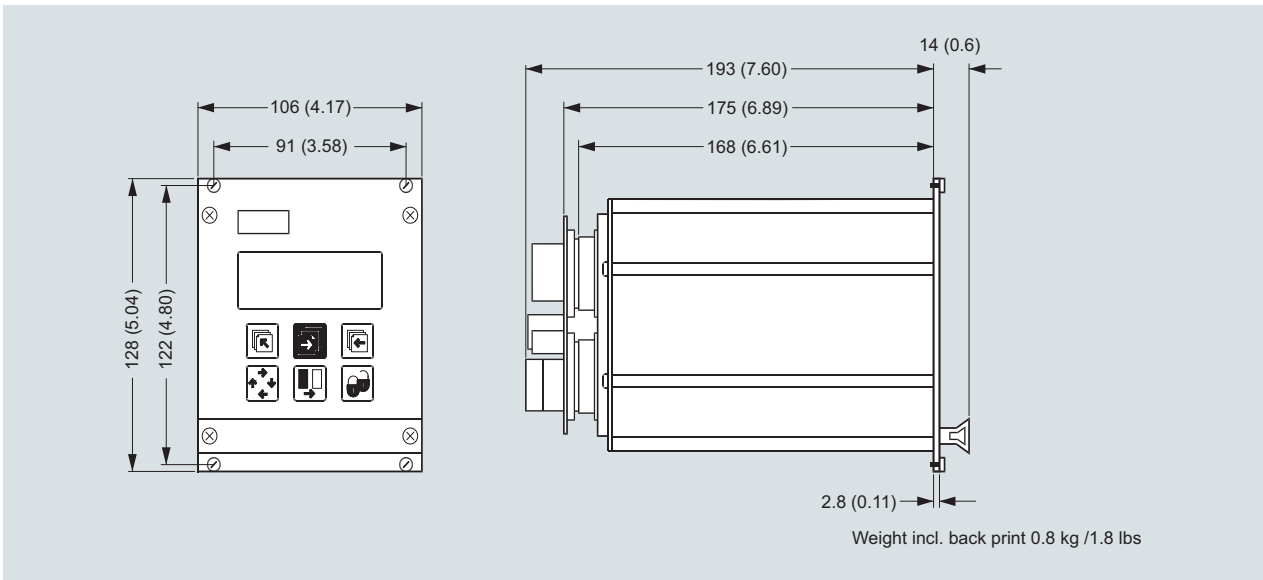

Dimensions in mm (inch)

Transmitter 19" wall mounting

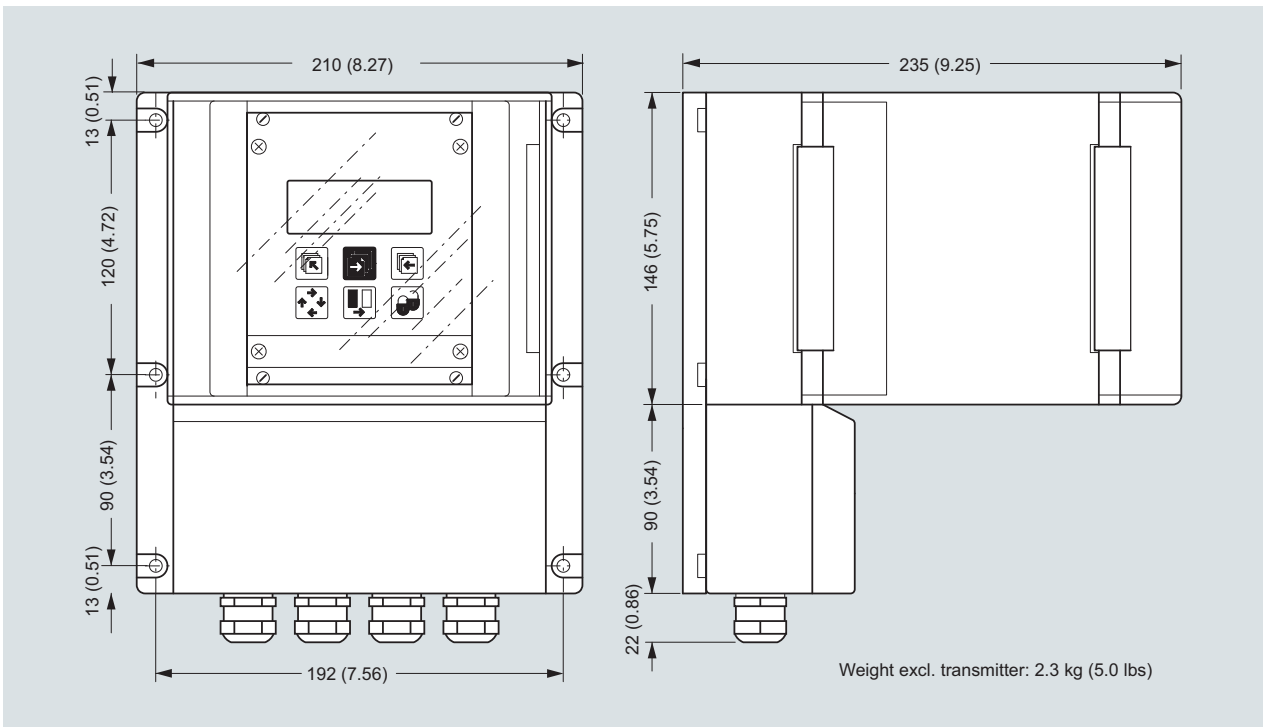

Dimensions in mm (inch)

Flow Measurement SITRANS F C

Transmitter MASS 6000
for 19" insert/19" wall mounting

Transmitter 19" front of panel

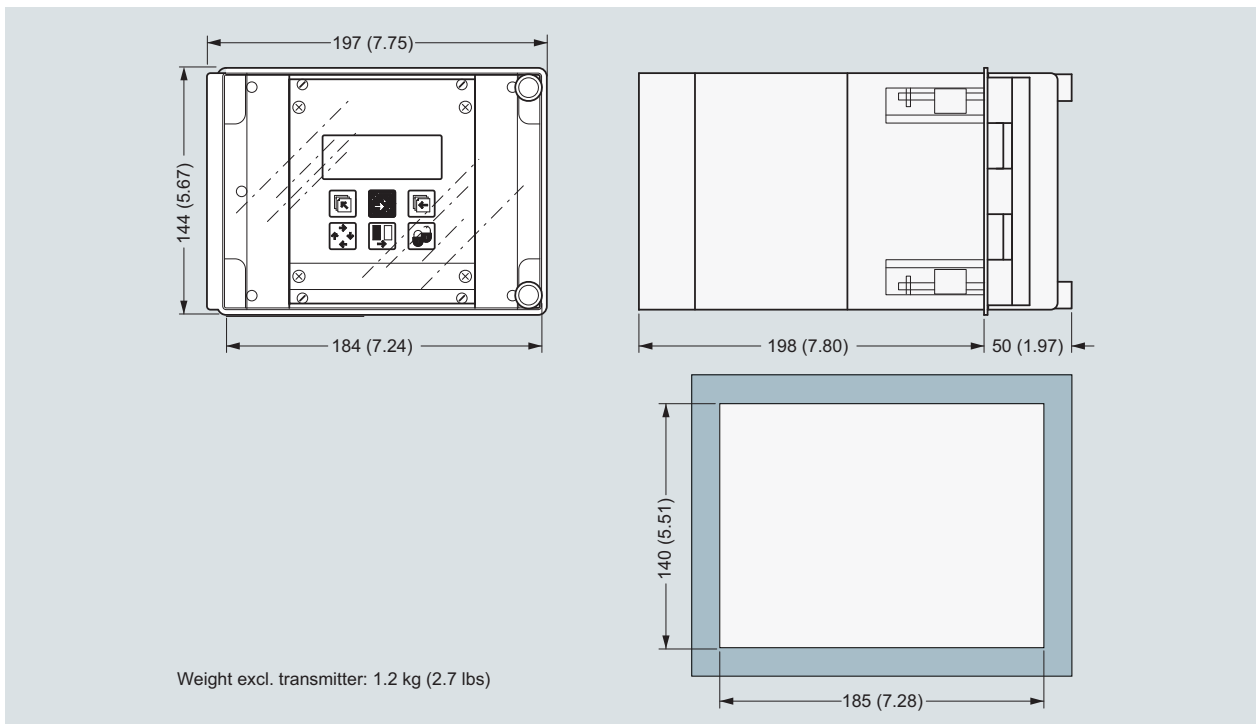

Dimensions in mm (inch)

Transmitter back of panel

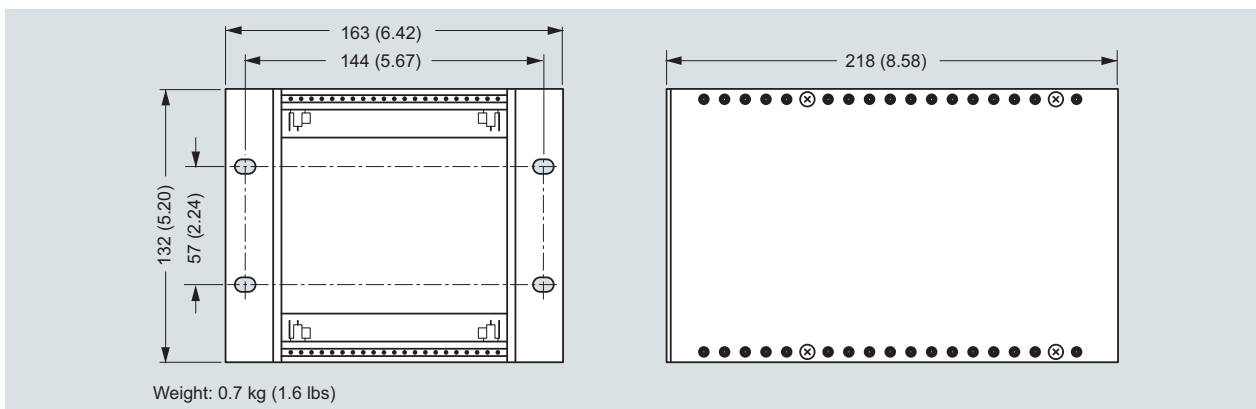

Dimensions in mm (inch)

Transmitter back of panel, 42 TE

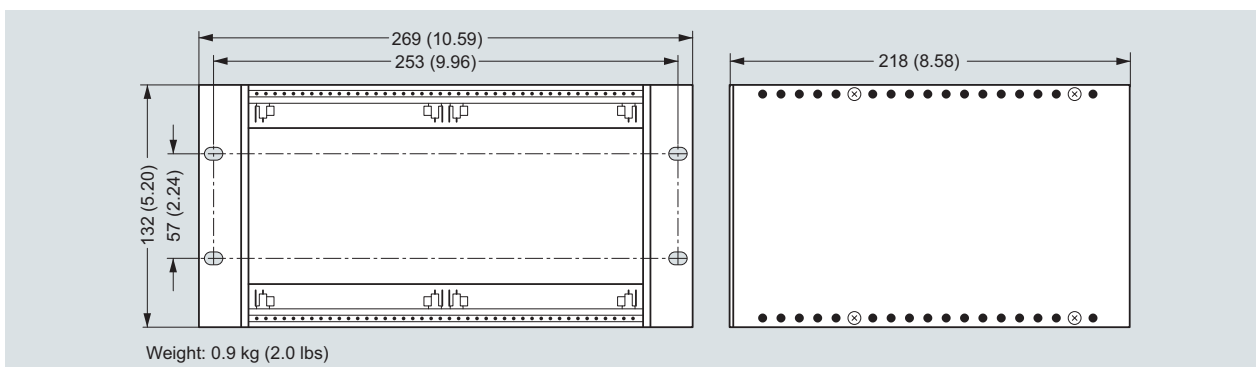

Dimensions in mm (inch)

Flow Measurement SITRANS F C

Transmitter MASS 6000
for 19" insert/19" wall mounting

Schematics

Electrical connection

Grounding

PE must be connected due to safety class 1 power supply.

Mechanical counters

When mounting a mechanical counter to terminals 57 and 58 (active output), a 1000 µF capacitor must be connected to the terminals 56 and 58. Capacitor + is connected to terminal 56 and capacitor - to terminal 58.

Output cables

If long cables are used in noisy environment, it is recommended to use shielded cables.

